

# WET WIPE TOILET PAPER DISPENSER WP119



172 x 79 x 135 mm

for one wet wipe toilet paper box

- Wet wipe toilet paper dispenser in robust, germ-reducing and easy-care stainless steel (AISI 304).
- All-stainless steel housing; visible surfaces satin finished and brushed.  
Further available surfaces: see below.
- Designed for one standard wet wipe toilet paper box with dimensions of approx. 165 x 78 x 121 mm
- Accessible through hinged lid.
- Mounting: With two screws through key holes and one optional anti-theft hole in the back wall.
- Delivery includes fixing material.
- Weight, including single package: 1.3 kg



## Suggested text for specifications:

Wet wipe toilet paper dispenser in stainless steel (AISI 304) for surface mounting. All-stainless steel housing; visible surfaces satin finished and brushed. Designed for one standard wet wipe toilet paper box. Accessible through hinged lid. Delivery includes fixing material.

Dimensions: 172 x 79 x 135 mm

Article No. WP119

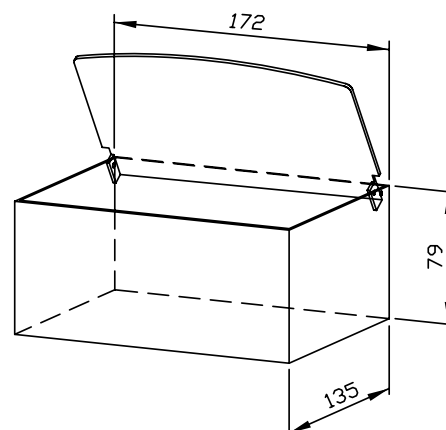

Available surfaces	ID No.
satin finished (standard)	727 525
highly polished	731 525
(coloured) plastic powder-coating	729 525

## Ernst Wagner GmbH & Co. KG

Ernst-Abbe-Straße 21 · D-72770 Reutlingen · Tel.: +49712151539-0 · Fax: -20  
info@wagner-ewar.de · www.wagner-ewar.de

WAGNER  
E W A R